

THIS MODEL IS NOT A TOY!

INSTRUCTION MANUAL

THESE INSTRUCTIONS SHOULD BE READ BY A SUPERVISING ADULT

2.4GHz RTR BINARY MICRO R/C CATAMARAN SAILBOAT

Model No:8807V3

IMPORTANT :

1. This is not a toy. Assembly and operating of this boat requires adult supervision.
2. Please take time to read the instructions carefully and completely before attempting to operate your model.
This manual contains the instructions you need to safely build, operate and maintain your R/C sailboat.

CONTENTS OF SET



BINARY catamaran hull
(Servos, receiver &
battery box pre-installed)



Sails & mast & booms set



Two PVC hatch sets



2.4GHz 2CH transmitter



CROSS-HEAD SCREWDRIVER - 1PC
(NOT INCLUDED)



Removable Keels

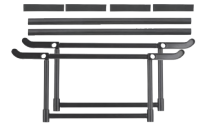

Boat stand set

IMPORTANT TIPS

Jib boom and main boom are installed with silicone O rings. Adjust rings position on booms so as to adjust jib sail and main sail closing and opening angle easily.

ITEMS REQUIRED FOR COMPLETION

- 4 x "AA" alkaline batteries for transmitter (not included)
- 3 x "AAA" alkaline batteries for receiver (not included)



FCC REQUIREMENT



This device complies with Part 15 of the FCC Rules. Operation is subject to the following two conditions: (1) This device may not cause harmful interference, and (2) This device must accept any interference received, including interference that may cause undesired operation.

CAUTION: Changes or modifications to this product not expressly approved by the party responsible for compliance may void the user's authority to operate the equipment.

BASIC BOAT TERMINOLOGY

BOW: The front of the boat.

STERN: The back of the boat.

PORT: This is the left side of the boat when view the boat from the stern. An easy way to remember this is that port and left both contain four letters.

STARBOARD: This is the right side of the boat when view the boat from the stern.

HULL: The body of the boat.

DECK: The top of the boat.

KEEL: A weighted blade that protrudes from the bottom of the hull as a means of providing lateral stability.

RUDDER: The hinged vertical plate mounted at the stern that controls steering.

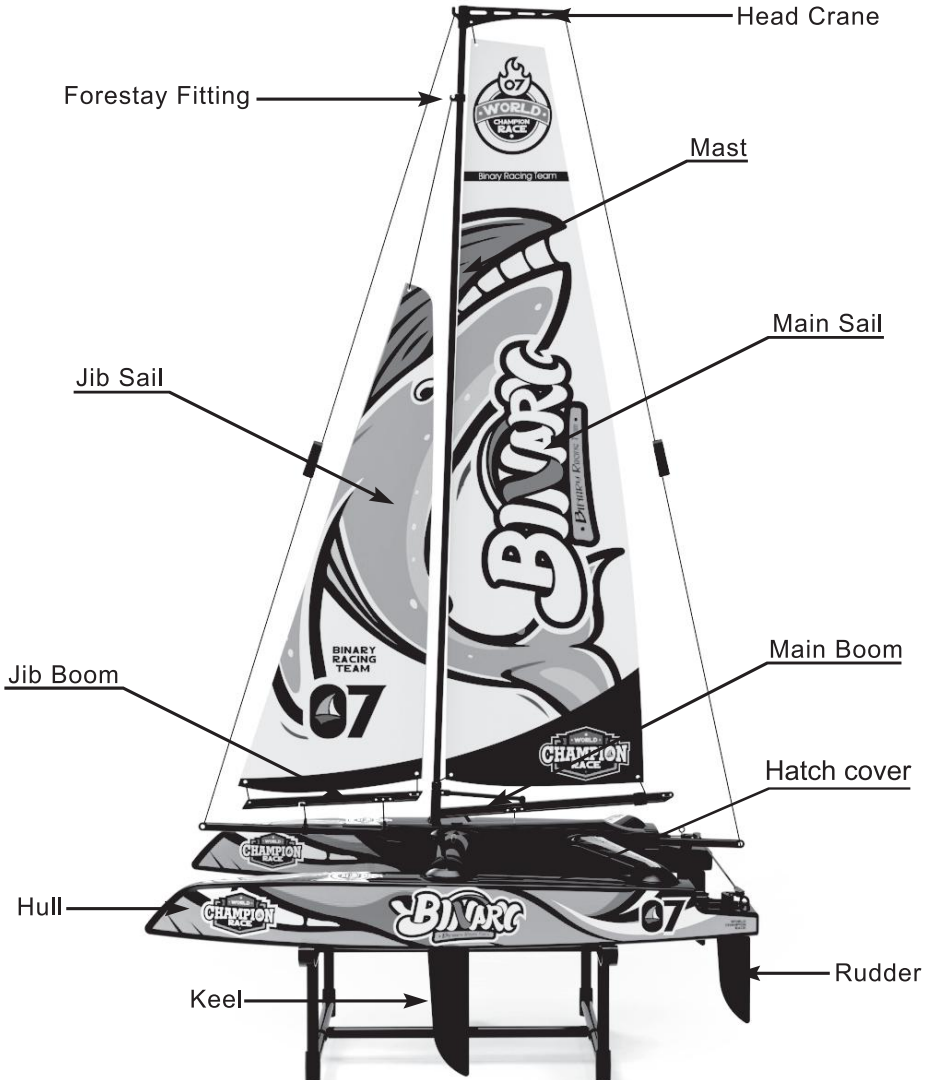

INSTALL 4 PCS "AA" ALKALINE BATTERIES IN YOUR TRANSMITTER



Always use fresh AA alkaline battery in the transmitter.

1. Ensure transmitter "POWER" switch is in the off position.
2. Slide off the battery door on the back of the transmitter.
3. Install 4 fresh "AA" alkaline batteries into the molded battery compartment of transmitter. Noting correct location (polarity + or -)
4. Re-install the battery door onto the back of transmitter.

NOTE: Suggest to keep the left stick (Throttle) on neutral position before switch on transmitter.

5. Switch on transmitter, you can hear "Bi" sound, transmitter green indicator light flash.

DISPLAY STAND ASSEMBLY

1. Assemble two pcs of side stand as photo shown.
2. Install two pcs of long tube between two side stand as photo shown.



3. Install four pcs of EVA on the hull support as shown. This will protect the hull bottom from scratches during construction and storage.

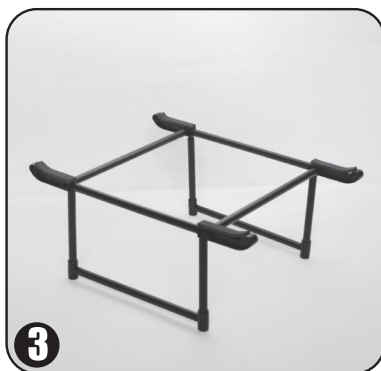
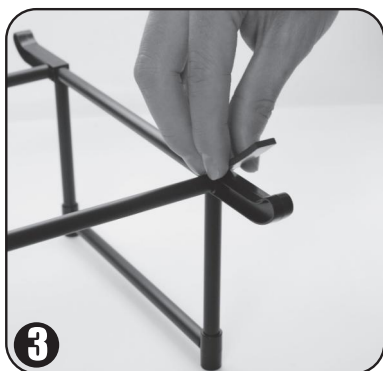

TAKE BOAT & SAILS OUT FROM BOX

1. Insert the two removable keels on the bottom of hulls as photo shown.
Notice the keel direction, make sure keel is fully pressed down and tight on hull.

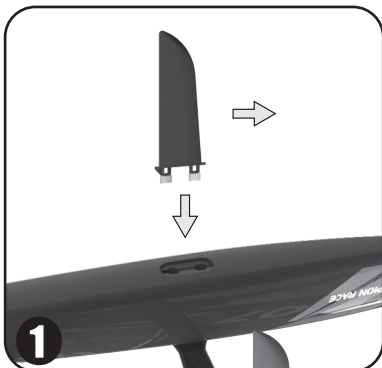

2. Place the boat on the display stand for next step assembly.
3. Take Sails & Mast & Booms set (pre-installed) out from box.



SAILS RIGGING

1. Insert Mast on the mast mount located on the central spar as photo shown.
2. Use cord on rear end of central spar to attach to hook of backstay crane as photo shown. Adjust cord bowsie to pull the backstay cord tight and straight.

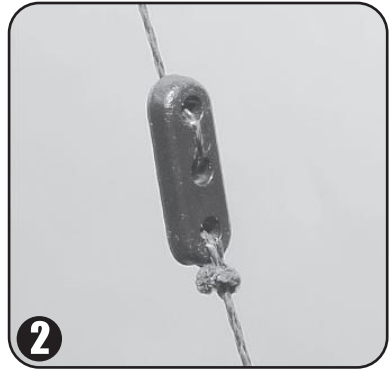
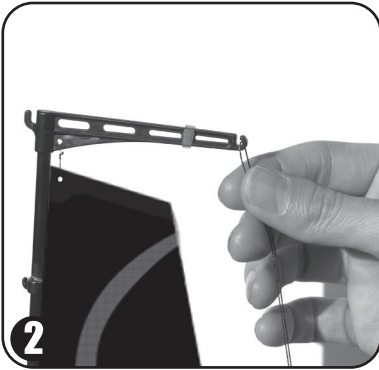
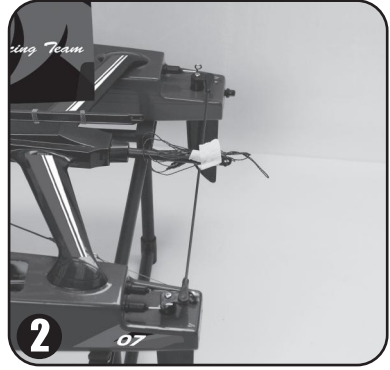
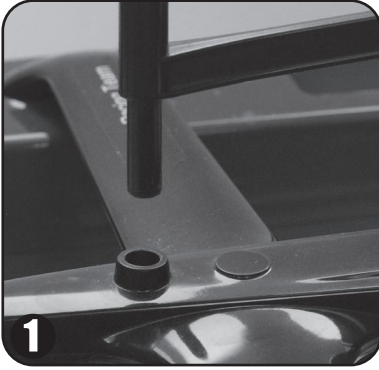

3. Use cord on front end of central spar to attach to hook of backstay crane as photo shown. Adjust cord bowsie to pull the forestay cord tight and straight.
4. Use forestay cord on jib sail tip to attach to hook of forestay fitting.

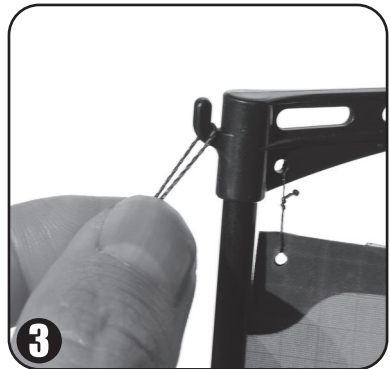
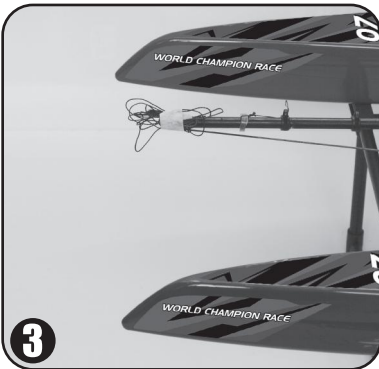

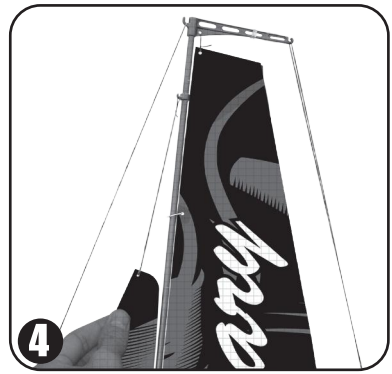
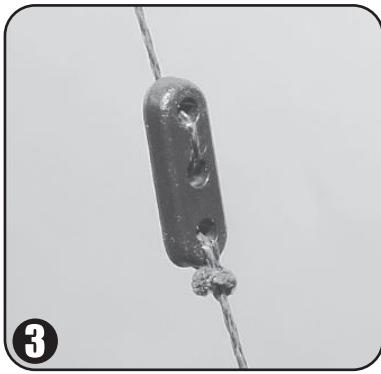

5. There is cord loop which attached to the silicone ring on central spar, use this cord loop to attach to hook underneath the jib boom. Adjust the silicone ring to pull cord tight.

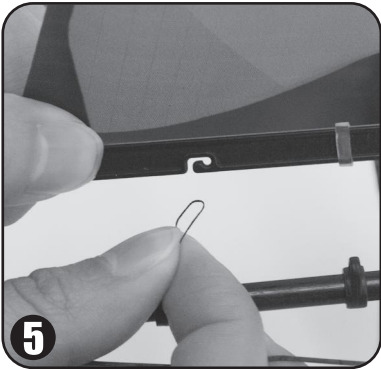

6. Use jib boom cord to thread through the second boom bend eye (from front side back to rear side) located in central spar, thread through the sheeting deck eyelet on forward cross beam, attach cord loop to the pin as photo shown.
7. Use main boom cord to thread through sheeting deck eyelet on center of cross beam, then thread through sheeting deck eyelet on forward cross beam, attach cord loop to the pin as photo shown.

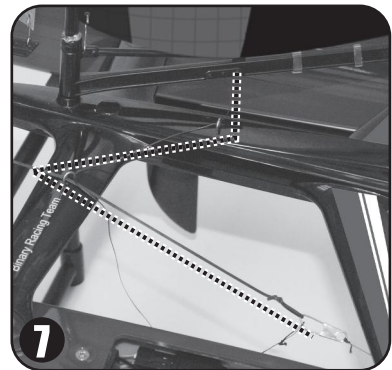
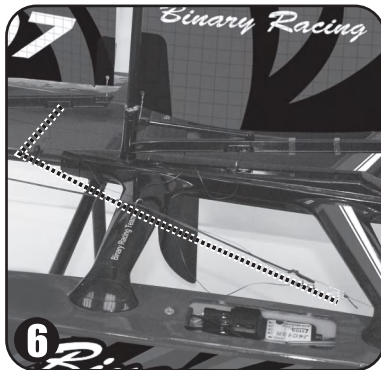

8. Adjust the B & C silicone ring on main boom to adjust the main sail radian as photo shown.

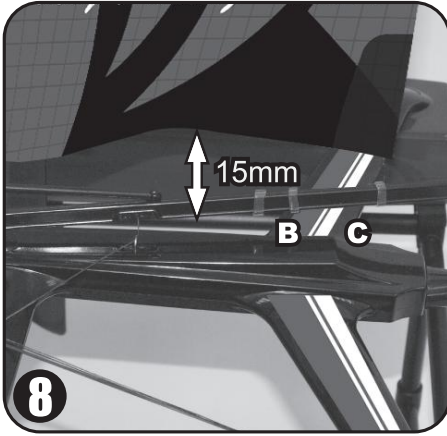

INSTALL 3 PCS “AAA” ALKALINE BATTERIES IN RECEIVER

IMPORTANT NOTE: Always switch on the transmitter before switch on the receiver and always switch off the receiver before switch off the transmitter.

Install 3 pcs AAA alkaline batteries into battery box of BINARY.

1. Keep the left stick (Throttle) on neutral position, Switch on transmitter.
2. Install 3 pieces of “AAA” Alkaline batteries into the receiver box,make sure the correct polarity. then fix battery box well with velcro strap.

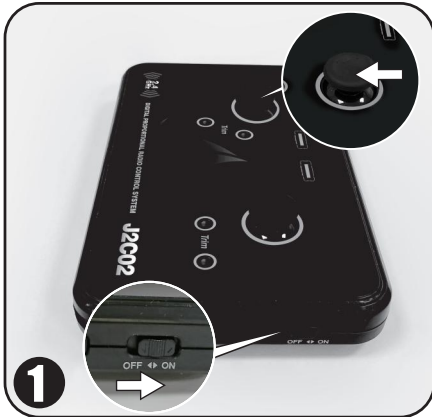

- Switch on the receiver by pushing the pushrod forward to position "ON". Receiver red light is on, transmitter make "Bi Bi" sound, transmitter green indicator light turn to solid on. Now both servos inside boat are under control correspondingly of radio control.

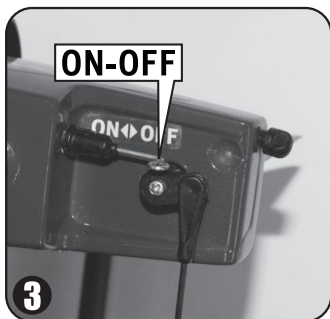

TRANSMITTER & RECEIVER BINDING

J2C02 transmitter and J2C02R(8807) receiver are automatically binding once they are power on. No need to press any bind button. Just make sure no other transmitter or receiver should be powered on near by.

PREPARATIONS FOR SAILING

Before sailing your BINARY for the first time, Always switch on the transmitter before switch on the receiver and always switch off the receiver before switch off the transmitter.

Following the procedures to check the radio and sailboat's function:

- For sail control stick, when stick is in position A, accordingly, the main boom and jib boom are in the position of A as shown. When stick is in the position of B, accordingly, the main boom and jib boom are in the position of B as shown.
- You may also adjust the sail servo neutral by pressing the sail neutral position trim button up or down.
- For rudder control stick, rudder turn left when rudder control stick is pushed to the left. Rudder turn right when rudder control stick is pushed to the right.
- You may also adjust the rudder servo neutral by pressing the rudder neutral position trim button left or right.
- Check to make sure the left and right rudder will move together in same direction when push rudder control stick on transmitter.

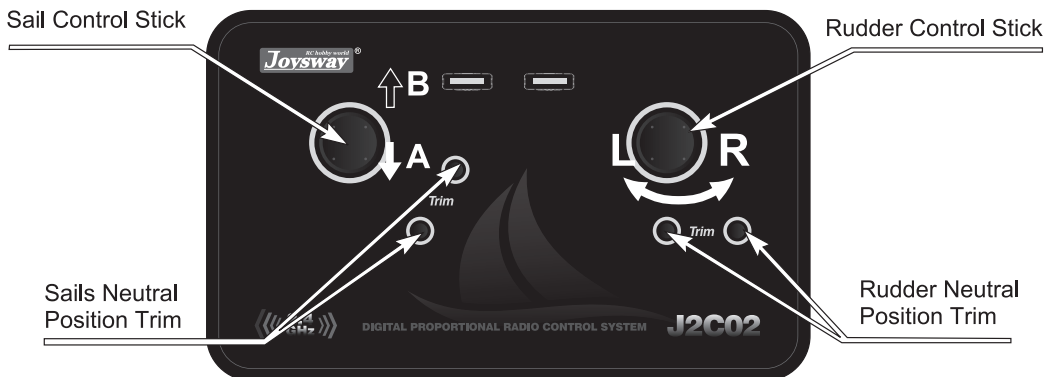

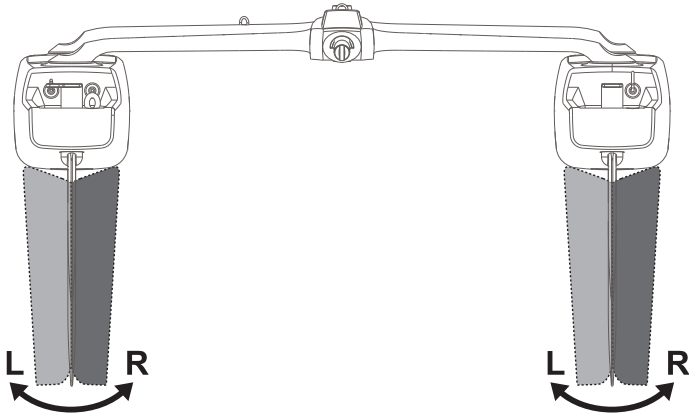
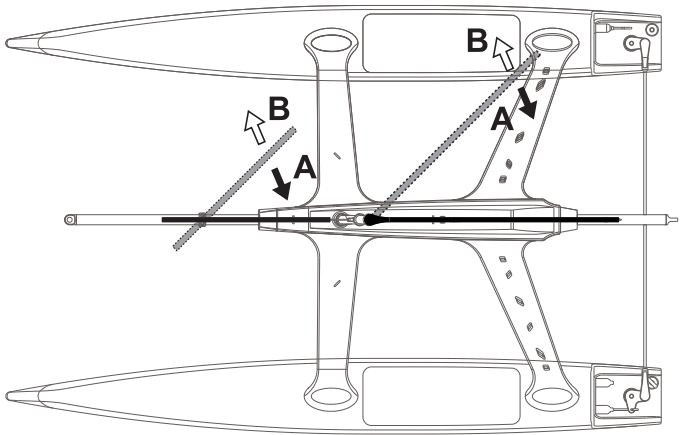

6. Adjust the silicone ring on central spar to pull jib boom tight.
7. Push down transmitter throttle stick (left stick) till its lowest position. This will make winch servo pull jib boom cord and main boom cord tight.
8. Adjust A silicone ring on main boom's position to make sure main boom is on the centerline of cross beam when winch servo pull main boom cord tight .

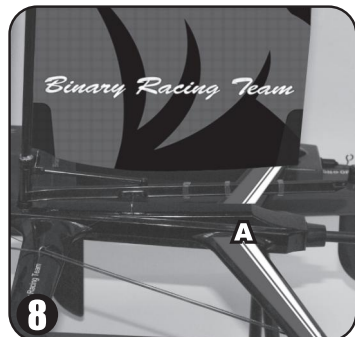

9. Adjust silicone ring on jib boom's position to make rear-end of Jib boom is moved away from mast at 15mm-20mm distance when winch servo pull jib boom cord tight.
10. Push up throttle stick till its top position, to check whether main sail and jib sail can be freely open or not.
11. Lastly stick the two pcs of PVC hatch on the hull deck. Press the PVC hatch tight on the deck.

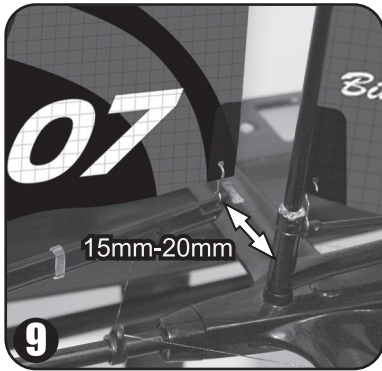

Smart Sails Control, Minimize Capsizing

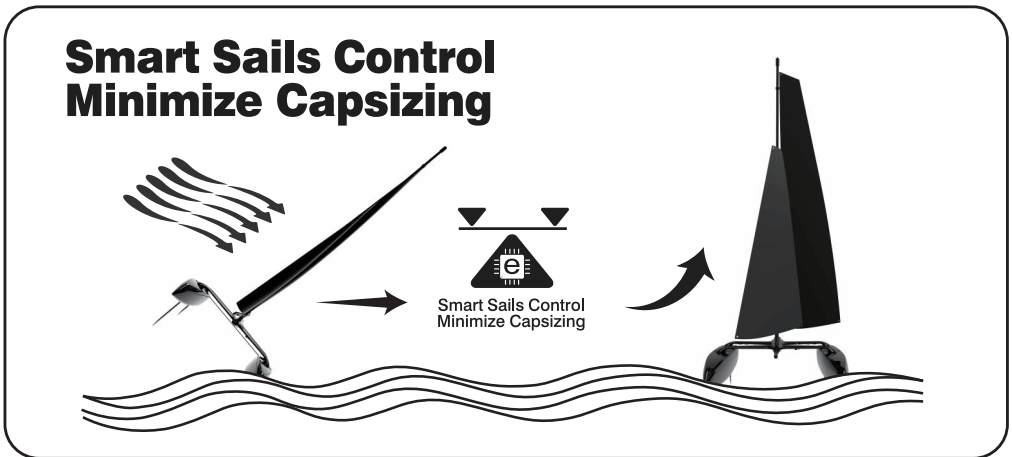

WHEN BOAT REACH THE DANGEROUS ANGLE OF INCLINATION IN GUST WIND, RECEIVER BUILT-IN INTELLIGENT ANGLE SENSING SYSTEM AUTOMATICALLY RELEASE SAILS, BOAT RETURN TO RIGHT POSITION, THE SMART SAILS CONTROL GREATLY MINIMIZE CAPSIZING.

SAILING THE BINARY

Unlike propeller driven boats that you basically point and accelerate, sailboats present an interesting challenge. Sailing requires constant reaction to water movements, any wind gusts, and any wind direction changes. These reactions then require adjustment of the rudder and sails in order to find the best possible course. There is no substitute for actual “on-the-water” experience and after your first couple of outings you may want to read through this manual again in order to help you to gain a better understanding of the “art” of sailing. While learning to sail, it is a good idea to pick up on as much sailing terminology as possible. This will make it easier to grasp some aspects.

How To Sail BINARY

Wind



Wind Abeam

Sails: Each at a position of 45°
Rudder: In center position

Quarter Lee

Sails: Letting both out a little more
Rudder: to the left

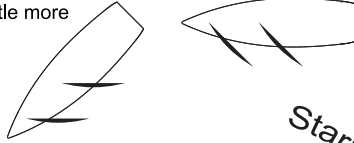

Bearing Away

Sails: Let both out so as not to shiver
Rudder: To the left



Starboard Tack -Running

Sails: Letting both out to their maximum position
Rudder: in center position



Port Tack - Close - Hauled

Sails: Keeping pulled in
Rudder: To be held at the center as long as the sails do not shiver

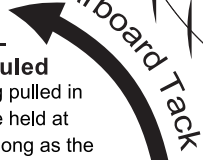

Tacking

Sails: Keeping pulled in
Rudder: To the left



Port Tack-Running

Sails: Letting both out to their maximum position
Rudder: in center position

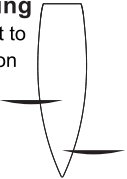

Tacking

Sails: Keeping pulled in
Rudder: To the right



Starboard Tack - Close - Hauled

Sails: Keeping pulled in
Rudder: To be held at the center as long as the sails do not shiver



Quarter Lee

Sails: Pulling both in a little
Rudder: In center position



Tacking

Sails: Keep pulled in
Rudder: To the left



Luffing Up

Sails: Pulling in bit by bit
Rudder: To the left



Port Tack - Close - Hauled

Sails: Keep pulling in
Rudder: To be held at the center as long as the sails do not shiver



Luffing Up

Sails: Pulling both in all the way
Rudder: To the left



START Wind Abeam

Sails: Each at a position of 45°
Rudder: In center position



IMPORTANT NOTICE:

1. Sail your BINARY only in still bodies of water. Never sail your boat in running water such as streams or rivers, as it is easy to lose control of your boat.
2. Do not sail BINARY in heavy winds.
3. Never attempt to swim after a stalled or stuck boat! Wait patiently for the wind currents to return the boat to shore.
4. After running, remove the deck and allow the interior of the boat to dry out completely. If you neglect to do this, it may result in corrosion of the electronic components.

SPARE PART LIST

#8807V3 Binary V3 catamaran sailboat spare part list

Part No	Description
----------------	--------------------

880704	deck covers (PK4)
880707	Stainless steel guiding parts for booms attachment (PK5)
880708	mainsail luff rings and sails attachment hook (pk5)
880709	Mast,booms and fittings set
880710	ABS Beam set
880711	Central spar and plastic fittings set
880713	ABS Rudder (PK2) and rudder linkage set
880714	Servo and battery box tray
880715	battery box for 3pcs AAA
880716	Pushrod with rubber bellow
880717	Power Switch rod w/ rubber bellow & switch connector set
880718	Plastic boat stand set
880719	6cm length silicone tube(3*5)
880720	9g sail and rudder servo (PK2)
880723	8807V2 &V3 left & right hull with black color painting, no decals
880724	8807V2 ABS keel (PK2)
880725	8807V3 main and jib sails set
880726	J2C02(8807V3) Receiver
880204	J2C02 2.4GHz 2CH transmitter
880320	5m dyneema cord 0.11mm
880511	1m Sheeting elastic
880518	5m length dyneema cord(0.4mm)
881210	Bowsie(PK10)
880536	Rubber bung (PK4)
880622	velco strap for battery box (PK2)
880623	winch line rubber cap (PK5)